

E-E (1 : 2)

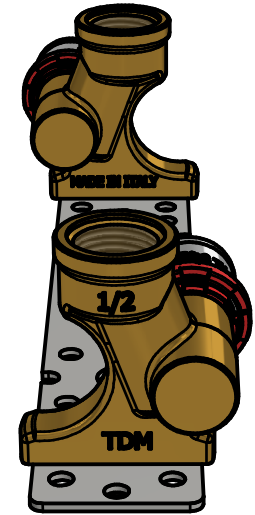
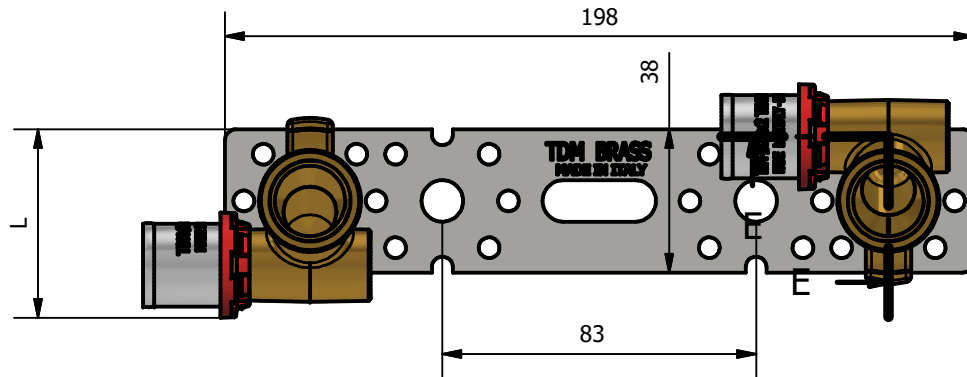
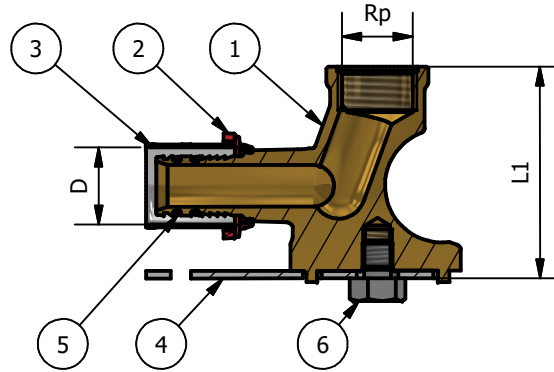

TDM CODE	SIZE	Rp	D	L	L1
1697C 1216	1/2x16	1/2	16x2	48	56
1697C 1218	1/2x18	1/2	18x2	49	56
1697C 1220	1/2x20	1/2	20x2	50	56

N°	DESCRIPTION	MATERIAL
1	BODY	CW 617N EN 12165
2	INSULATION RING	NAYLON 6 (Red)
3	BUSH	AISI 304 EN 10088-2
4	WALLPLATE	STELL DD10
5	O-RING	EPDM PEROX
6	SCREW	STELL

CONFORMITY	
1) DM 37 del 06/04/2004	
2) UNI EN 10954-2	
3) UNI EN 1254-3	
4) UNI EN 10226-1 (ISO 7-1)	
5) UNI EN 681-1	

WORKING PRESSURE MAX	10 BAR
WORKING TEMPERATURE MIN- MAX	-20°C / 120°C

00	Prima emissione		Delaini M.	28/06/2017
Rev.	Nota Revisione		Approvatore	Data Approvazione
Toll Gen:	JS13	Stato sup.:	Giallo Sabbiato	
Filetto:	ISO 7-1	Note tecniche:		
Peso lavorato:	Peso grezzo:	N° stampo:	Codice: 1697C scheda	
Materiale:			Disegnatore:	Data: 28/06/2017
			Delaini P.	
Descrizione: Staffa con raccordi disassati terminali				
TDM Brass s.r.l via Artigiani , 7-9 25030 Maclodio BS Italy tel +39 030 9972217 fax 030 9787089 www.tdmbrass.it email info@tdmbrass.it				

